

Metro

Prepaid

SUB METERS FOR TENANTS



GRGC16M CE

**Sentinel Range Garage Unit (IP20)
with 63A RCCB Type A + 16A and 6A MCBs**

The distribution equipment and circuit protection range of metal consumer units by Europa Components are designed to fully comply with the requirements of BS EN 61439-3 and the requirements of the 18th Edition of BS 7671 IET Wiring Regulations. With multiple configurations available, the range offers flexible versatile solutions for installations.

Features & Benefits

- Includes 63A Type A RCCB, 16A MCB B Curve and 6A MCB B Curve.
- Type A RCCB also suitable for Type AC applications.
- Compact and unobtrusive design for restricted spaces.
- Metal enclosure, suitable for domestic application.
- Epoxy powder coated RAL 7035.
- Earth and neutral terminals provided.
- Labels included for easy identification.
- Comes pre-wired, ready to install out of the box.



Metro

Prepaid

SUB METERS FOR TENANTS

GRGC16M CE



Standards

Device	RCCB	MCB
Standard	BS EN 61008-1	BS EN 60898-1

Cable and Torque Settings

Device	RCCB	MCB
Max Cable Capacity (mm ²)	35	16
Recommended Tightening Torque (Nm)	2.5	2.0

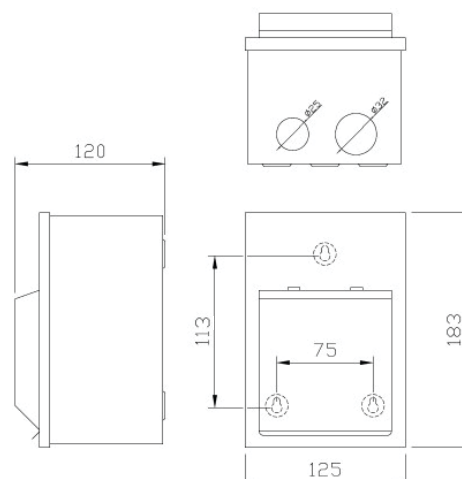

Notes

- This unit must be installed by a skilled or instructed person in accordance with the current BS 7671 IET Wiring Regulations.
- The product must be tested by skilled persons competent for verification after installation and before being put to service.
- Please ensure these instructions are available to the end user for future reference.
- Total load not to exceed the rating of the incoming main switch or RCCB.
- It is important to ensure that all connections, including factory-made, must be checked for the correct installation and tightness, prior to the commissioning of the electrical installation.
- This product is only suitable for indoor installation.